



SNG
NOVA GORICA

PRODUCER: SNG NOVA GORICA

TENA ŠTIVIČIĆ 64

Director: Nina Šorak

Duration: 2 hours, no break

Number of actors: 7

Transportation of equipment: External transport

TECHNICAL REQUIREMENTS

STAGE

Minimum width: 7 m portal

Minimum depth: 10 m

Minimum height: 4.5 m

Number of fly bars: 3

Number of lighting bars: 3

More photos and info: <https://www.sng-ng.si/sl/repertoar/arhiv-predstav/64/>

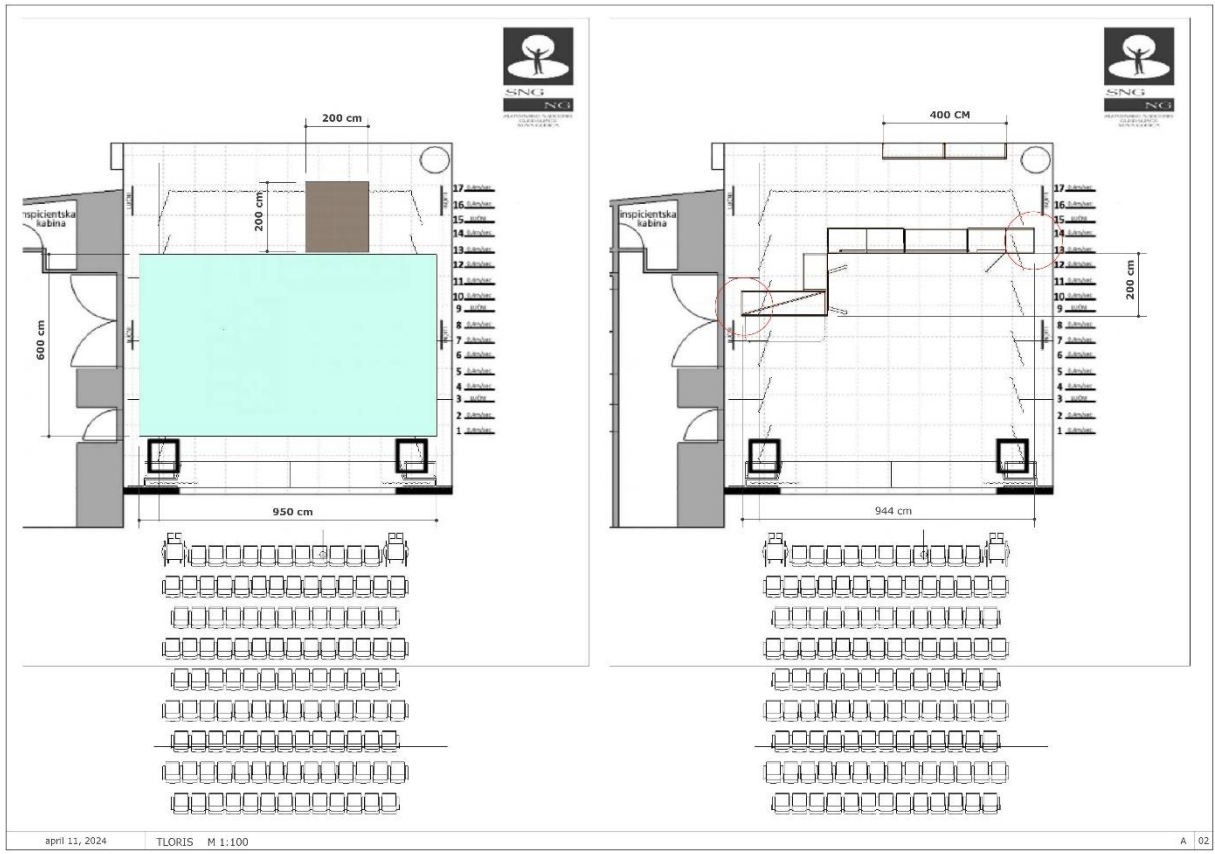

LIGHTING PLAN

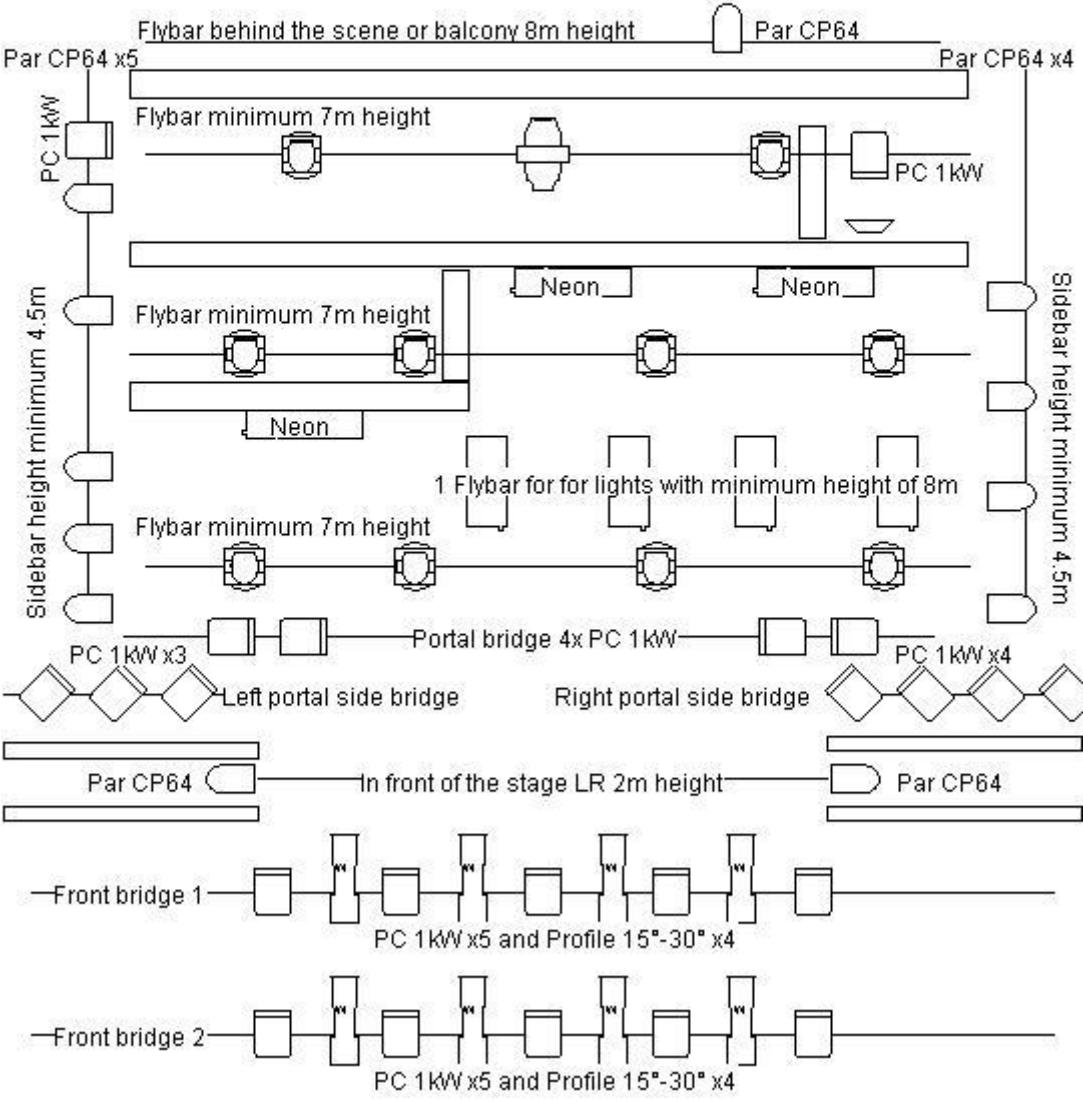

SOUND

Microphones:

1 x Sennheiser SKM 2000 handheld wireless microphone

1x AKG 451 condenser microphone

4 x SM 58

Stands:

2x stand with base (e. g. K&M 26050)

Sound system:

1x full range horizon

2x full range side fill

L-R main PA

L-R surround (surround back)

Yamaha M7CL or equivalent.

It should be placed in the auditorium with visibility of the entire stage. A closed cabin is not acceptable.

Input 6x mic + 5x sound card (if Dante not available)

Output 7 (separate lines to PA)

220V 16A tone electricity, separate from lamp electricity.

We need the help of a sound engineer for installation and regulation.

We will bring our own computer, everything else should be provided by the host.

WARDROBES

Number of dressing rooms: 3 actresses and 4 actors

We need a makeup room with a mirror and a dressing room(s) with showers and towels.

TECHNICAL TEAM

Provided person by producer:	Provided person for help by host:
Transportation 1	Transportation 0
Unloading 4	Unloading 2
Setting up scenography 4	Setting up scenography 2
Light 2	Light 1
Wardrobe 2	Wardrobe 0
Mask 2	Mask 0
Sound 1	Sound 1
Video 0	Video 0
Props 1	Props 0
Disassembling 4	Disassembling 2

WORKING HOURS – Reference Plan of work

Day of the performance	8.00	Unloading
	8.30	Setting up scenography
	10.00	Setting up lights
	13.00	Setting up sound
	17.00	Setting up props
	18.00	Make up and costumes
	20.00	Performance
	22.00	Disassembling and loading

The schedule is adjusted according to the arrival of the technical staff and the time of the performance.

SUBTITLES

Subtitle translation from Slovenian is arranged by the producer. Subtitles are guided by the producer.

Provided by the host:

- projector (6000 Ansi Lumens or more)
- VGA cables
- basis for projection

Vodja sektorja tehničnih služb / Head of Technical Services **Davorin Kodrič**

T: +386 (0)5 335 22 14

M: +386 (0)41 318 911

E: davorin.kodric@sng-ng.si

Producent / Producer **Aleksander Blažica**

T: +386 (0)5 335 22 14

M: +386 (0)31 683 323

E: aleksander.blazica@sng-ng.si

Oblikovalec svetlobe / Lighting **Marko Vrkljan** T: +386 71 430 868

Odrski mojster / Master stage technician **Damir Ipavec** T: +386 70 855 893

Oblikovalec zvoka / Sound **Jure Mavrič** T: +386 40 184 886